

Implementace ATM služeb v mezinárodní síti

Vysokorychlostní síť 1999

Praha, 12.11. 1999

Agenda

- **ATM & FR Overview**
- **Service Overview**
- **ATM Product Overview**
- **FR Product Overview**
- **Pricing**
- **Fault Reporting**
- **Product Summary**

ATM & FR Overview

Worldwide Frame Relay Services Market Revenue by Geographic Region

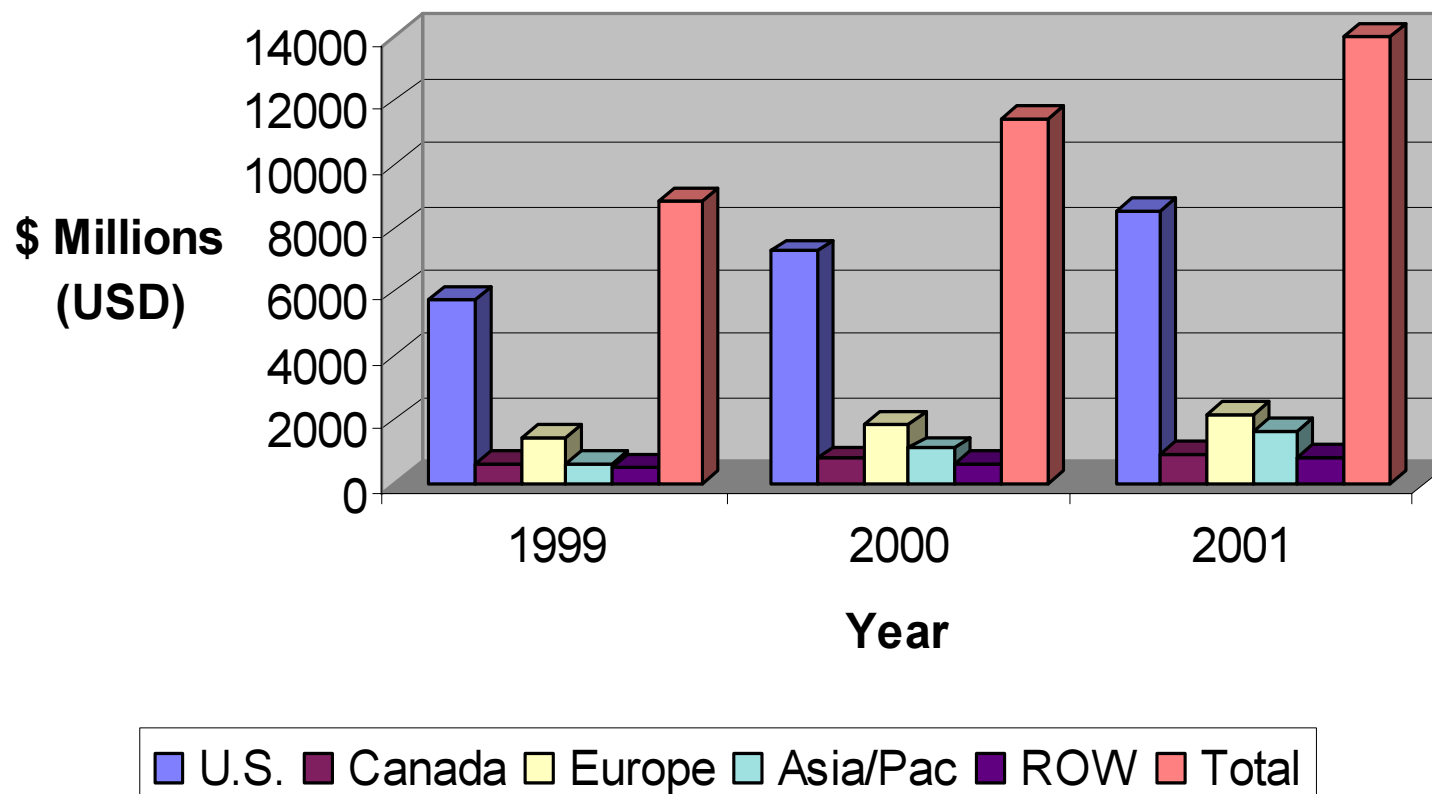

Source: Verticle Systems Group, 1998

Worldwide ATM Service market Revenue by Geographic Region

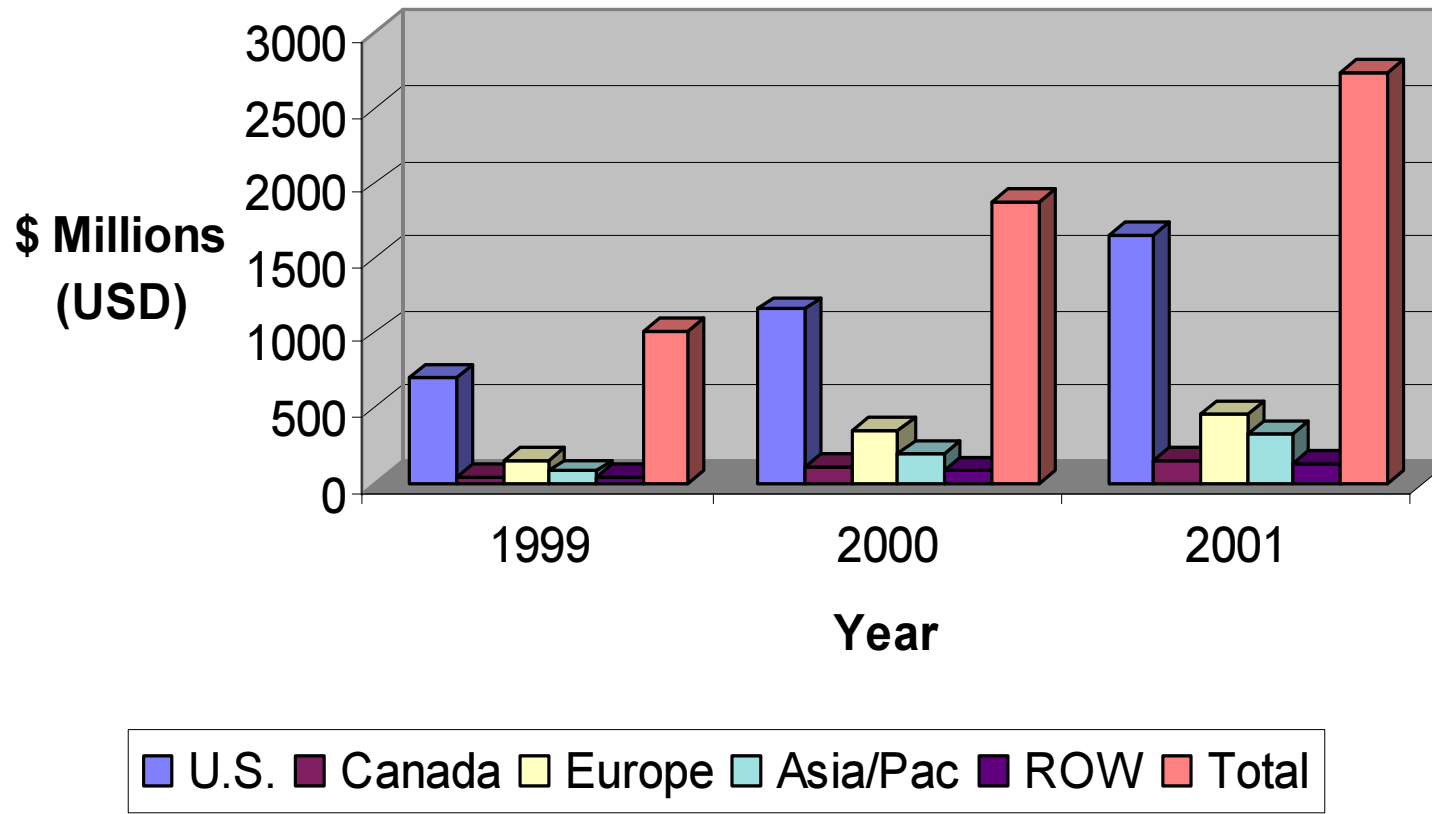

Source: Verticle Systems Group, 1998

Characteristics of ATM / Frame Relay

The Best of Both World's

Statistical Multiplexing:

- Network Switching
- Statistical Multiplexing
- Bandwidth Efficiency

Time Division Multiplexing:

- Protocol Insensitivity
- High Speed
- Low Delay

Bandwidth Efficiency

High Speed

Multiple Protocols

Optimized Resources

What is Frame Relay Technology?

Definition

A Fast packet Transport Technology That takes advantage of:

- Error-free Digital transmission Facilities
- Intelligent End-user Devices

To Deliver:

- Flexibility and reliability similar to X.25 packet switching
- High Throughput and Low Delay similar to that of private lines (TDM)

What is ATM Technology?

Definition

A fast packet transport technology carrying mixed traffic types in a sequence of fixed length cells (53 bytes). The capacity of each cell can be allocated to any user for video, data or voice traffic.

To Deliver:

- Network integration of voice, video and data
- More bandwidth
- Flexible Access Speeds
- Dedicated bandwidth per connection
- Well defined connection procedures
- Effective congestion management
- Built-in migration from Frame Relay

Frames vs. Cells

Frame Relay Frame



- Frame lengths are variable - up to 4096 octets for some applications
- Frames are best suited to statistical sharing of bandwidth for bursty data

Asynchronous Transfer Mode Cell



- Cells have a fixed length of 53 octets
- Cells can carry video, image, bursty data or voice

Benefits of ATM / FR Service

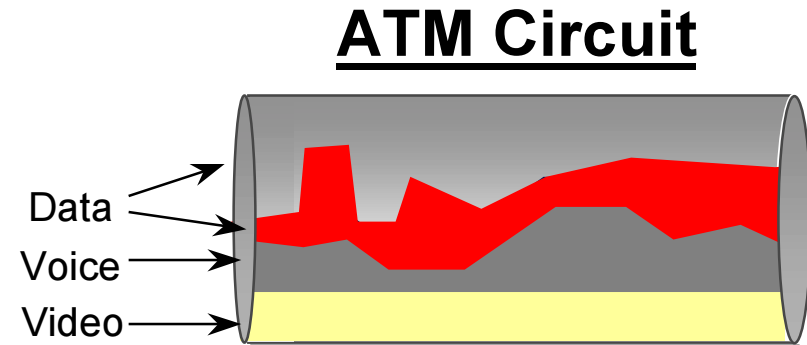
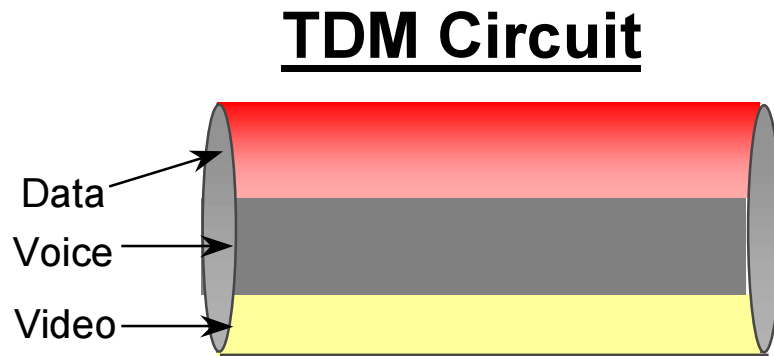

- **Only Consumes Bandwidth on an “As Needed Basis”**
- **Unconsumed Bandwidth Available to Other Circuits**
- **Accommodates Bursty Data Traffic**
- **Able to Reserve Bandwidth for High-Priority Applications**
- **Greater Bandwidth Efficiency \Leftrightarrow Lower Cost**

Reasons Why Customers Buy Wholesale ATM and Frame Relay

ISPs

- Scalable, Inexpensive Access to Internet Transit Networks
- Interconnect Service Locations / Add New Service Locations
- Transport for Over-flow Traffic and Traffic Aggregation

Carriers / PTTs / LEC

- Scalable, Inexpensive Access to Internet Transit Networks
- Wholesale Frame Relay and ATM Service to Enhance Carriers/PTTs/LEC Local Frame Relay and ATM Service
- Specialty Services - VOIP Distributed STARTAP for R&E
- Transport for Over-flow Traffic and Traffic Aggregation

Emerging Carriers

- Scalable, Inexpensive Access to Internet Transit Networks
- Scalable, Inexpensive Access to Voice Transit Networks (VOIP)
- Wholesale Frame Relay and ATM Service to Enhance Local Frame Relay and ATM Service offering

Service Overview

Teleglobe ATM Service Overview

- Non-Switched Service
- Point-to-Point Connections
 - Virtual Paths
 - Virtual Channels
- Three ATM Service Classes Supported
 - Constant Bit Rate
 - Variable Bit Rate (real time) - VBR Plus (Teleglobe Network only)
 - Variable Bit Rate (non-real time) - VBR
- Peak Cell Rates from 64 Kb/s to 155 Mb/s
 - > 45 Mb/s provided on a case-by-case basis
- Flat Rate Billing
- Enhanced Services for 1999
 - DS1 & E1 AAL1 Circuit Emulation
 - Frame Relay Service (Service and Network Interworking)
 - VOIP over ATM

Teleglobe Frame Relay Service Overview

➤ Access Rates - Port Speed

- 64Kb/s to 2.048 Mb/s in 64 Kb/s increments
- DS1 or E1
- DS3/E3 High-Speed Port Access

➤ CIR Rates

- 25% Port Speed
- 50% Port Speed

➤ Burst Capability - EIR equal to Port Speed

➤ Frame-to-ATM Interworking (Service or Network)

➤ Flat Rate Billing

➤ Standards Support

- ANSI T1.618; ANSI 1.617 Annex D
- ITU 1.122Q.922 Annex A, Core aspects or Q.922 for use with Frame Relay

ATM Service Cable Access

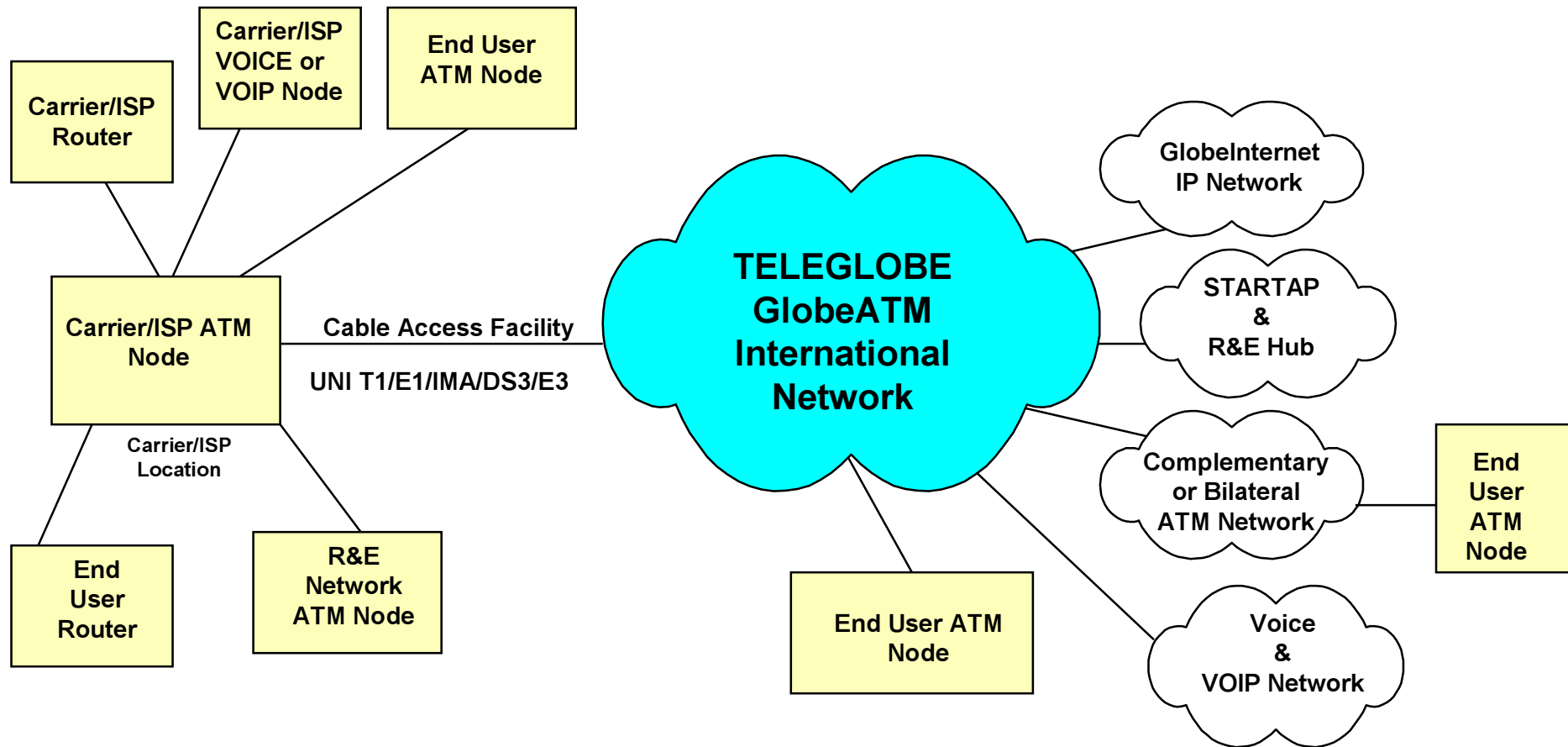

Frame Relay Cable Access Configuration

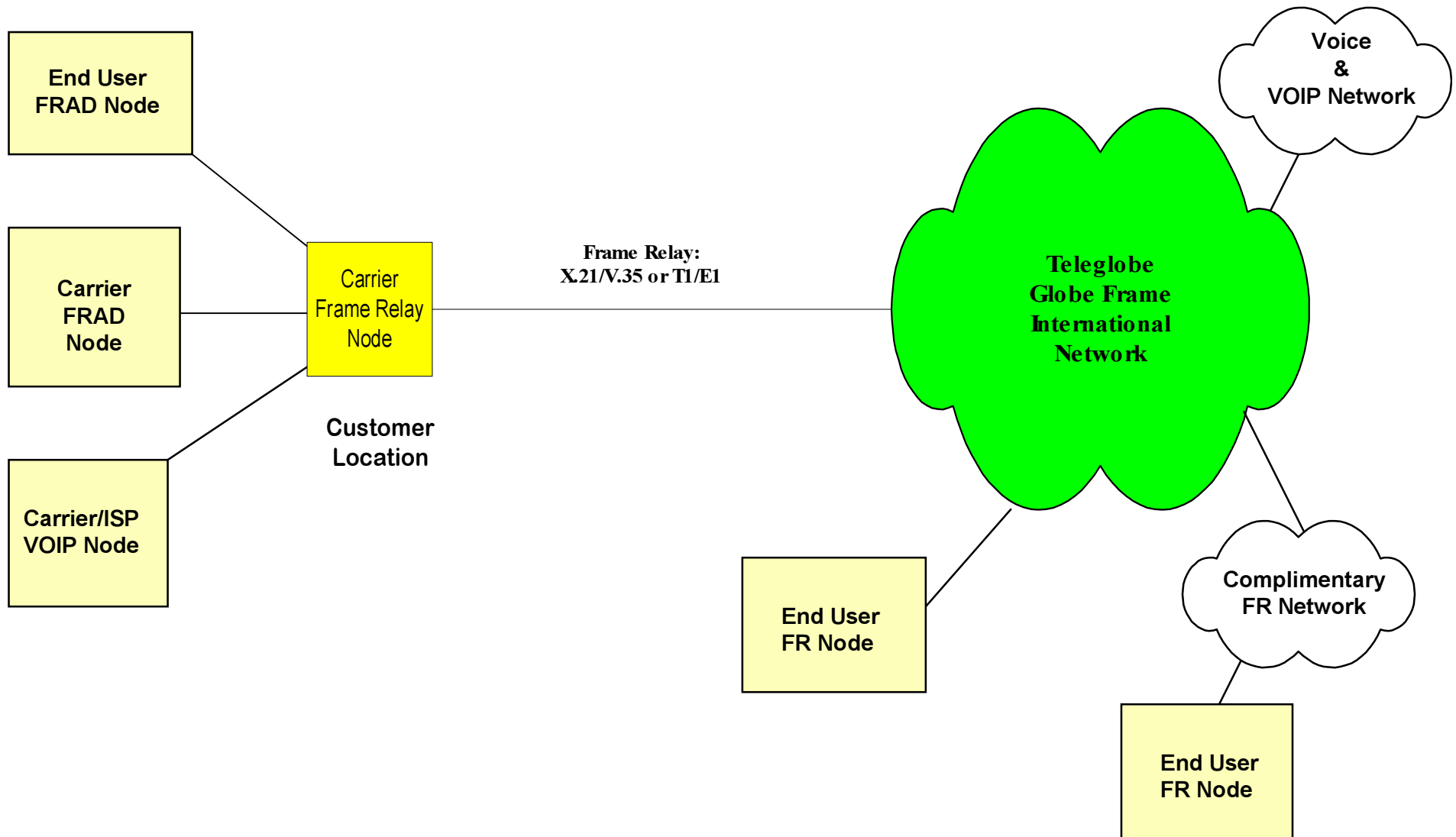

Teleglobe ATM Network Access

	Bandwidth	Customer Premise MUX Equipment
North American Hierarchy	OC-3 (155 Mbps)	No
	DS3 (45 Mbps)	No
	NxDS1 (up to 8 T1's)	Yes
	DS1 (1.544 Mb/s)	No
European Hierarchy	STM-1 (155 Mbps)	No
	E3 (34 Mbps)	No
	NxE1 (up to 8 E1's)	Yes
	E1 (2.048 Mb/s)	No

Frame Relay Network Access

Access Location	Standard CIR Rules	Standard Port: CIR Ratio Rules	
Direct	CIRs equivalent to either 25% or 50% of port speed	<u>Port Speeds:</u> 56/64Kbps – 45Mbps	<u>CIR Options:</u> 16 – 22Mbps
Complementary Service Provider - IXC	<p>For 56Kbps or 64Kbps, any CIR (minimum 4K) can be ordered up to 50% of port speed</p> <p>For ≥ 128Kbps, any CIR (minimum 4K) can be ordered up to 50% of port speed. HOWEVER, the maximum burst capability is limited to 4X the subscribed CIR value.</p>	<p><u>Port Speeds:</u> 56/64Kbps</p> <p>128Kbps – 1536Kbps</p>	<p><u>CIR Options:</u> 4, 8, 16 or 32Kbps</p> <p>4, 8, 16, 32, 48, 56, 64, 128, 192, 256, 320, 384, 448, 512, 576, 640, 704, 768Kbps</p>

ATM & Frame Relay - 3Q'99

North American Network Topology

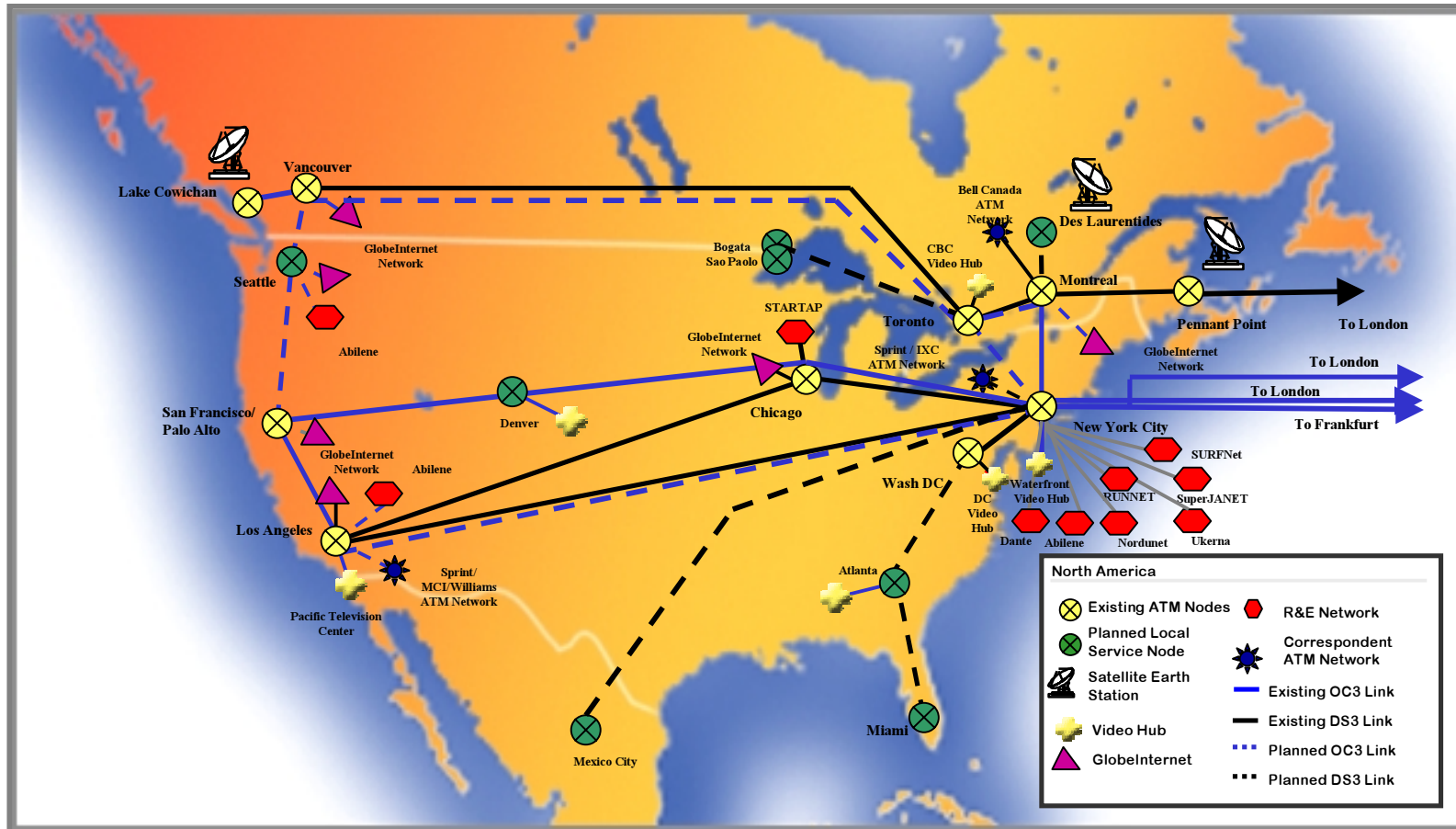

ATM & Frame Relay - 3Q'99

European Backbone Network

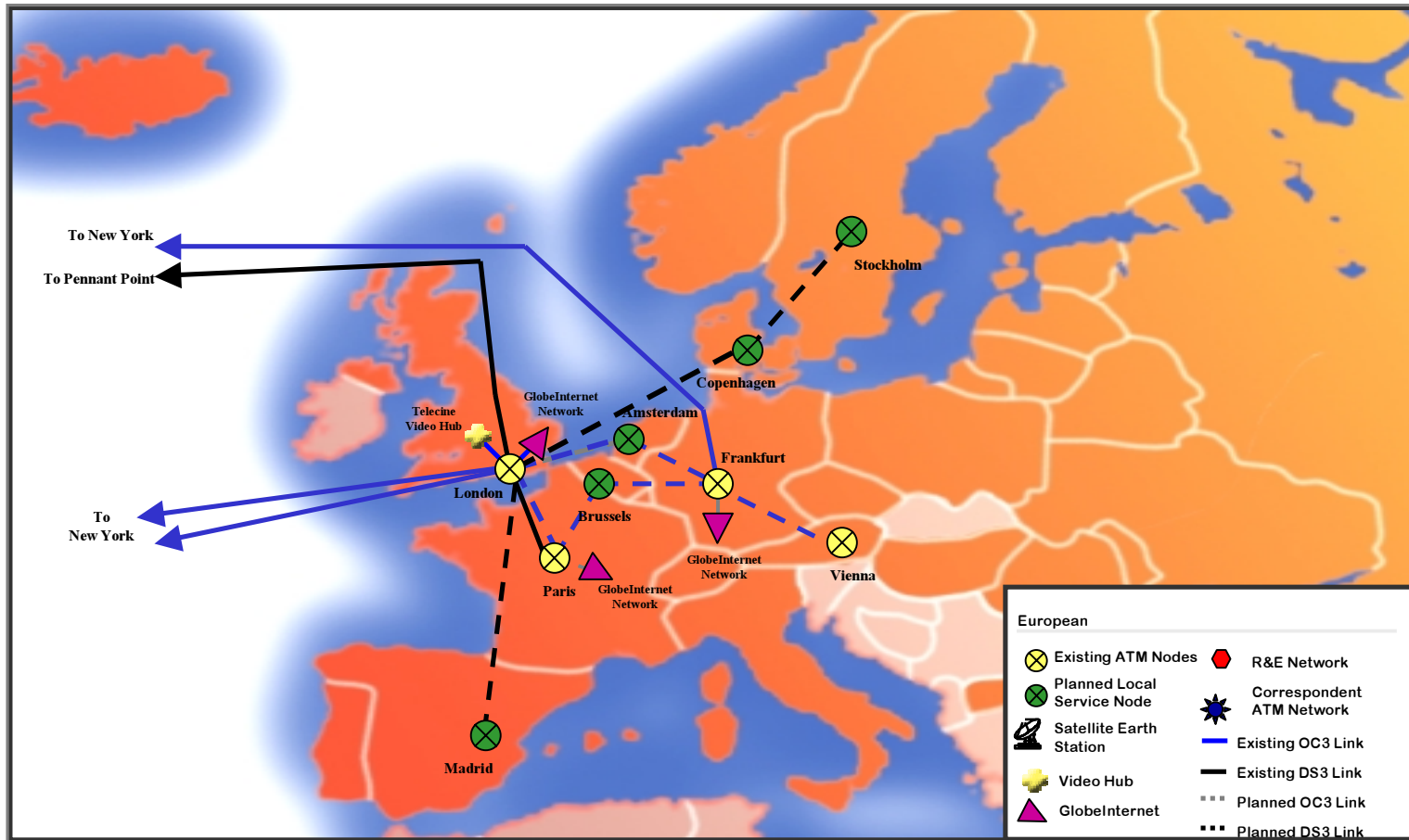

ATM / Frame Relay Service Locations

City	ATM Port Speed				COS
	E1/DS1	IMA	E3/DS3	STM1/OC3	
1. New York	Now	4Q'99	Now	Now	CBR; VBR; VBR-rt
2. Chicago	Now	4Q'99	Now	4Q'99	CBR; VBR; VBR-rt
3. Los Angeles	Now	4Q'99	Now	4Q'99	CBR; VBR; VBR-rt
4. Montreal	Now	4Q'99	Now	Now	CBR; VBR; VBR-rt
5. London	Now	4Q'99	Now	Now	CBR; VBR; VBR-rt
6. Frankfurt	Now	4Q'99	Now	Now	CBR; VBR; VBR-rt
7. Paris	Now	4Q'99	Now	4Q'99	CBR; VBR; VBR-rt
8. Pennant Point	Now	4Q'99	Now	TBD	CBR; VBR; VBR-rt
9. Vancouver	3Q'99	4Q'99	Now	4Q'99	CBR; VBR; VBR-rt
10. Toronto	3Q'99	4Q'99	3Q'99	TBD	CBR; VBR; VBR-rt
11. Washington DC	Now	4Q'99	3Q'99	TBD	CBR; VBR; VBR-rt
12. Palo Alto	Now	4Q'99	Now	Now	CBR; VBR; VBR-rt
13. Amsterdam	1Q'00	1Q'00	1Q'00	1Q'00	CBR; VBR; VBR-rt
14. Brussels	2Q'00	2Q'00	2Q'00	2Q'00	CBR; VBR; VBR-rt
15. Copenhagen	1Q'00	1Q'00	1Q'00	TBD	CBR; VBR; VBR-rt
16. Vienna	Now	4Q'99	4Q'99	TBD	CBR; VBR; VBR-rt
17. Madrid	1Q'00	1Q'00	1Q'00	TBD	CBR; VBR; VBR-rt
18. Bogata	1Q'00	1Q'00	TBD	TBD	CBR; VBR; VBR-rt
19. Sao Paolo	1Q'00	1Q'00	TBD	TBD	CBR; VBR; VBR-rt
20. Stockholm	3Q'00	3Q'00	3Q'00	3Q'00	CBR; VBR; VBR-rt
21. Oslo	1Q'00	1Q'00	1Q'00	TBD	CBR; VBR; VBR-rt
22. Zurich	2Q'00	2Q'00	2Q'00	TBD	CBR; VBR; VBR-rt
23. Milan	3Q'00	3Q'00	3Q'00	3Q'00	CBR; VBR; VBR-rt

**•12 Sites & 6 Countries
available today**

**•23 Sites & 16 Countries
by 3Q'00**

**•PVC service, all service
classes, E3/DS3 access,
STM-1 access standard
in 18 locations**

Complimentary Provider ATM Network

IXC's U.S. ATM Locations

- Abilene, TX
- Akron, OH
- Albany, NY
- Amarillo, TX
- Appleton, WI
- Asheville, NC
- Atlanta, GA
- Austin, TX
- Baltimore, MD
- Baton Rouge, LA
- Birmingham, AL
- Boise, ID
- Boston, MA
- Bowling Green, KY
- Buffalo, NY
- Camden, NJ
- Charlotte, NC
- Chattanooga, TN
- Cincinnati, OH
- Cleveland, OH
- Colorado Springs
- Columbus, OH
- Columbia, SC
- Corpus Christie, TX
- Dallas, TX
- Dayton, OH
- Denver, CO
- Des Moines, IA
- Detroit, MI
- El Paso, TX
- Fairfax, VA
- Flint, MI
- Fortworth, TX
- Greenwood, IN
- Greensboro, NC
- Harlington, TX
- Hartford, CT
- Hattiesburg, MS
- Hayward, CA
- Houston, TX
- Hudson, OH
- Indianapolis, IN
- Irvine, CA
- Jackson, MS
- Jacksonville, FL
- Joplin, MO
- Kansas City, MO
- Knoxville, TN
- Las Vegas, NV
- Laurinburg, NC
- Little Rock, AR
- Longview, TX
- Lubbock, TX
- Louisville, KY
- McAllen, TX
- Memphis, TN
- Miami, FL
- Midland, TX
- Milwaukee, WI
- Minneapolis, MN
- Nashville, TN
- New Bern, NC
- New Orleans, LA
- Newark, LA
- Newark, DE
- Newark, NJ
- Norfolk, VA
- Oklahoma City, OK
- Orlando, FL
- Palmdale, CA
- Philadelphia, PA
- Phoenix, AZ
- Pittsburgh, PA
- Pontiac, MI
- Portland, OR
- Raleigh, NC
- Reno, NV
- Richmond, VA
- Rochester, NY
- Sacramento, CA
- Saginaw, MI
- Salinas, CA
- Salt Lake City, UT
- San Antonio, TX
- San Diego, CA
- San Jose, CA
- Santa Barbara, CA
- Seattle, WA
- Shreveport, LA
- South Bend, IN
- St. Louis, MO
- Stockton, CA
- Tallahassee, FL
- Tampa, FL
- Toledo, OH
- Tucson, AZ
- Tulsa, OK
- Waco, TX
- West Palm Beach, FL
- Winchester, KY
- Winona, MN
- Youngstown, OH

Complimentary Provider Frame Relay Network

IXC's U.S. Frame Relay Locations

- Abilene, TX
- Akron, OH
- Albany, NY
- Albuquerque, NM
- Amarillo, TX
- Appleton, WI
- Asheville, NC
- Atlanta, GA
- Austin, TX
- Baltimore, MD
- Baton Rouge, LA
- Birmingham, AL
- Boise, ID
- Boston, MA
- Bowling Green, KY
- Buffalo, NY
- Camden, NJ
- Charleston, SC
- Charlotte, NC
- Chattanooga, TN
- Cincinnati, IL
- Cleveland, OH
- Colorado Springs, CO
- Columbia, SC
- Columbia, GA
- Columbus, OH
- Corpus Christie, TX
- Dallas, TX
- Dayton, OH
- Denver, CO
- Des Moines, IA
- Detroit, MI
- El Paso, TX
- Fairfax, VA
- Flint, MI
- Ft. Lauderdale, FL
- Ft. Worth, TX
- Greenville, SC
- Greenwood, IN
- Greensboro, NC
- Harlington, TX
- Hartford, CT
- Hattiesburg, MS
- Hayward, CA
- Houston, TX
- Indianapolis, IN
- Irvine, CA
- Irving, TX
- Jackson, MS
- Jacksonville, FL
- Joplin, MO
- Kansas City, MO
- Knoxville, TN
- Las Vegas, NV
- Laurinburg, NC
- Lexington, KY
- Little Rock, AR
- Longview, TX
- Louisville, KY
- Lubbock, TX
- McAllen, TX
- Memphis, TN
- Miami, FL
- Midland, TX
- Milwaukee, WI
- Minneapolis, MN
- Mobile, AL
- Montgomery, AL
- Nashville, TN
- New Bern, NC
- New Orleans, LA
- Newark, LA
- Newark, DE
- Newark, NJ
- Norfolk, VA
- Oklahoma City, OK
- Orlando, FL
- Palmdale, CA
- Philadelphia, PA
- Phoenix, AZ
- Pittsburgh, PA
- Pontiac, MI
- Portland, OR
- Raleigh, NC
- Reno, NV
- Richmond, VA
- Rochester, NY
- Sacramento, CA
- Saginaw, MI
- Salinas, CA
- Salt Lake City, UT
- San Antonio, TX
- San Diego, CA
- San Francisco, CA
- San Jose, CA
- Santa Barbara, CA
- Santa Clara, CA
- Savannah, GA
- Seattle, WA
- Shreveport, LA
- South Bend, IN
- Spartanburg, SC
- St. Louis, MO
- Stockton, CA
- Tallahassee, FL
- Tampa, FL
- Toledo, OH
- Tucson, AZ
- Tulsa, OK
- Tysons Corner, VA
- Waco, TX
- West Palm Beach, FL
- Winchester, KY
- Winona, MN
- Youngstown, OH

ATM CBR Service

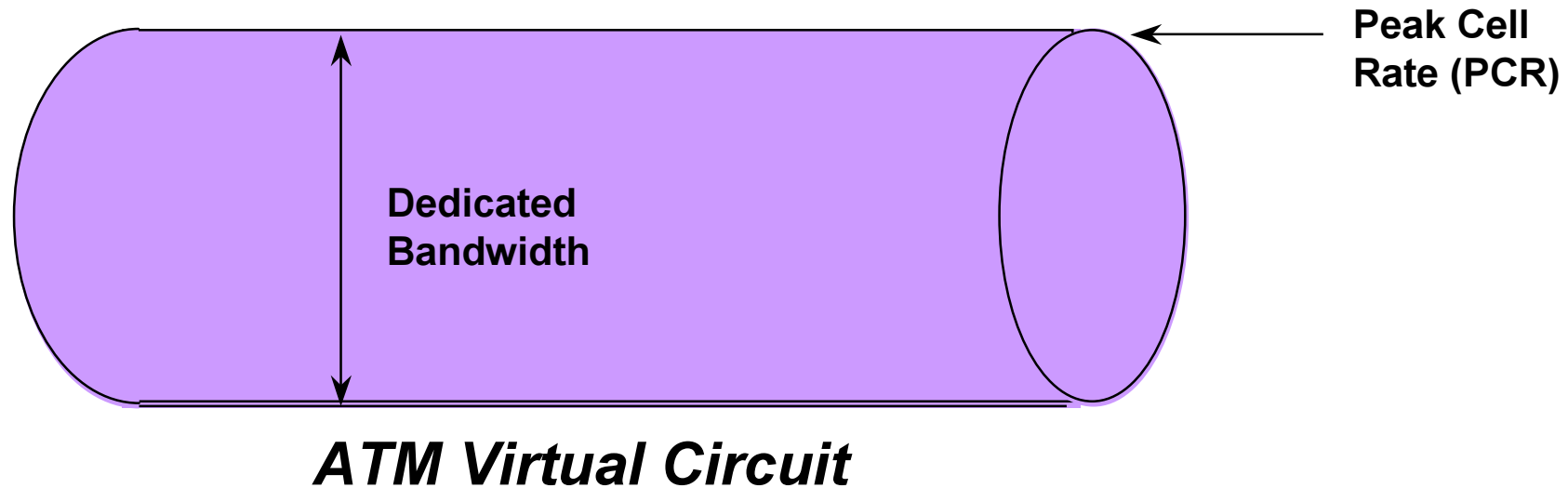

- **All Bandwidth Dedicated**
- **Burst Bandwidth Not Available**
- **Highest Priority Traffic = Lowest Delay**
- **Multiple PCR Rates Available**

ATM VBR Service

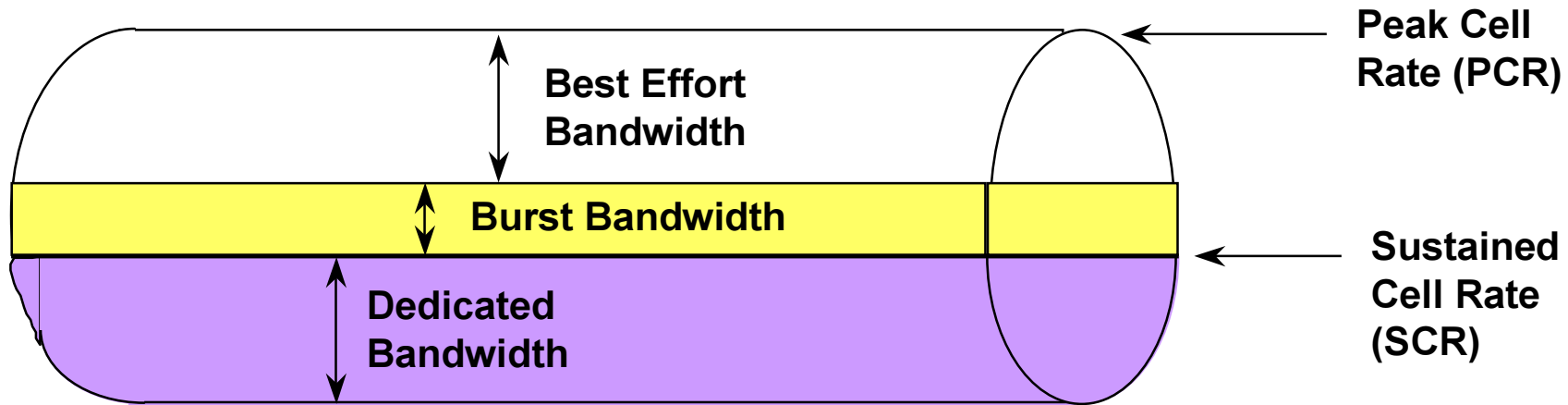

ATM Virtual Circuit

- **Dedicated = Anticipated Traffic**
- **Burst = Anticipated Data Bursts**
- **Best Effort = Unanticipated Data Bursts**
- **Multiple Combinations of PCR & SCR Available**
- **Low Priority/Delay Insensitive Traffic**

ATM

VBR Plus Service

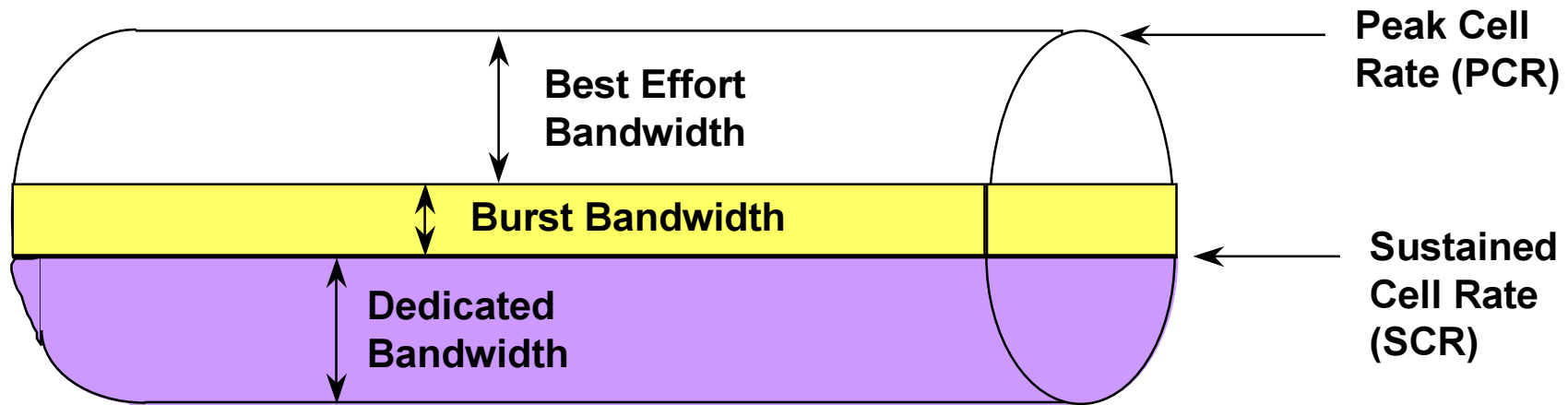

ATM Virtual Circuit

- **Dedicated = Anticipated Traffic**
- **Burst = Anticipated Data Bursts**
- **Best Effort = Unanticipated Data Bursts**
- **Multiple Combinations of PCR & SCR Available**
- **High Priority/Delay Sensitive Traffic**

ATM UBR Service



ATM Virtual Circuit

- **Lowest Price Service Option**
- **Utilizes Available B/W Within The Network**
- **Good For Overflow Traffic or Backup Circuits**
- **Good For File Transfer Applications**
- **Available on a Case-by-Case Basis**

Frame Relay Service

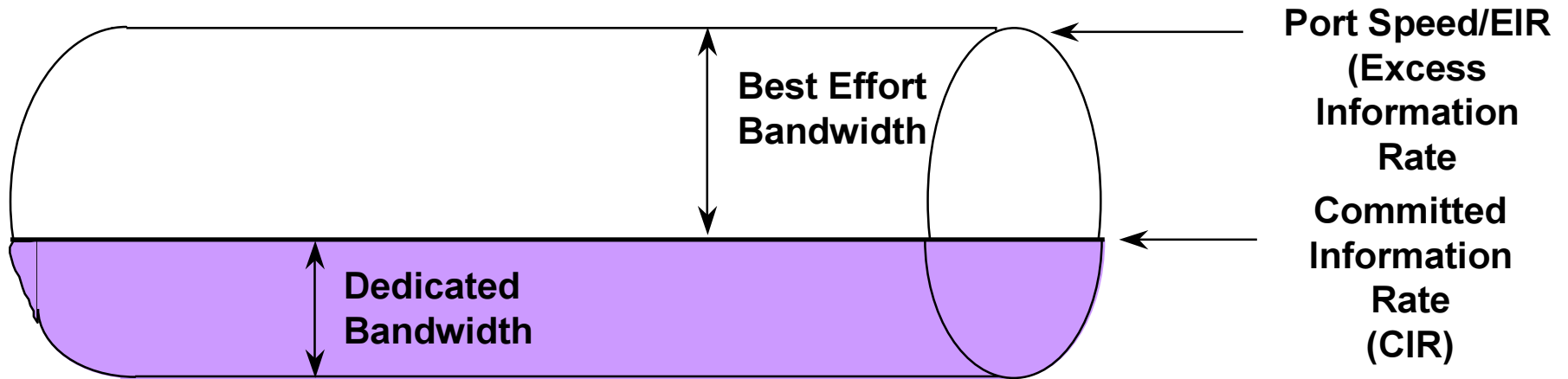

ATM Virtual Circuit

- **Dedicated = Anticipated Traffic**
- **Best Effort = Network Bandwidth Available for Data Bursts**
- **Ratio Port Speed to CIR - 2:1 or 4:1**

Product Overview

ATM Internet Access Service Configuration

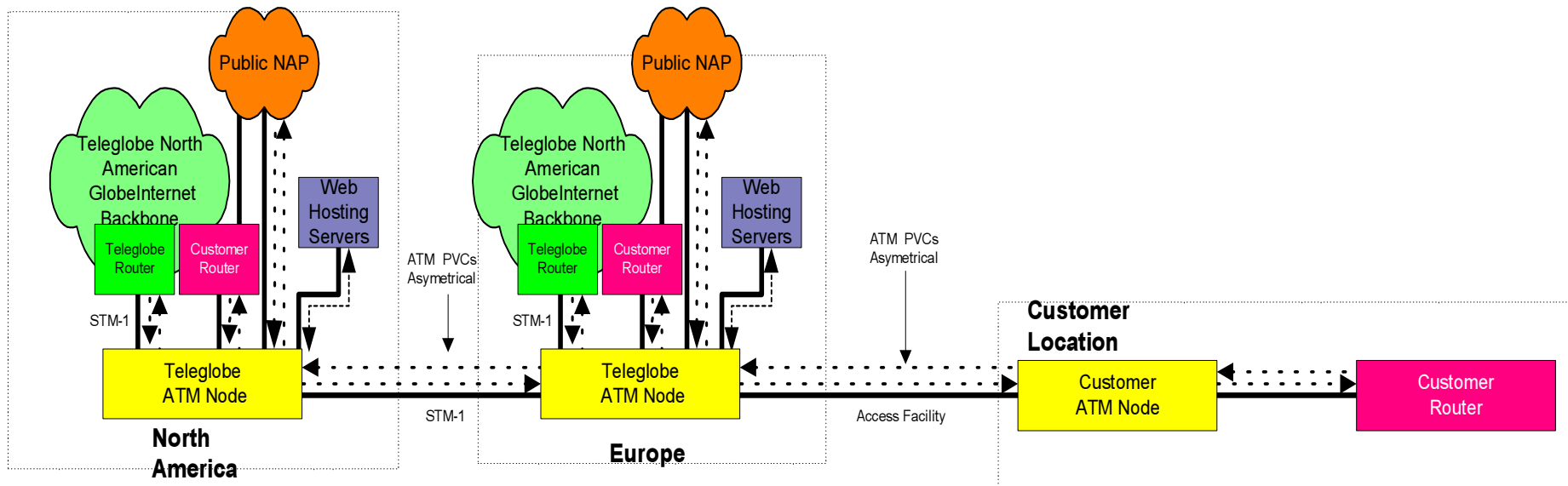

- Internet Access to Geographic Regions (Europe and North America)
- Scalable Bandwidth
- Application Specific Circuit Configurations (i.e. streaming media, video, etc.)
- Asymmetrical Internet Transit Circuits
- Access to Regional NAPs

Case Study #1 - TP S.A.

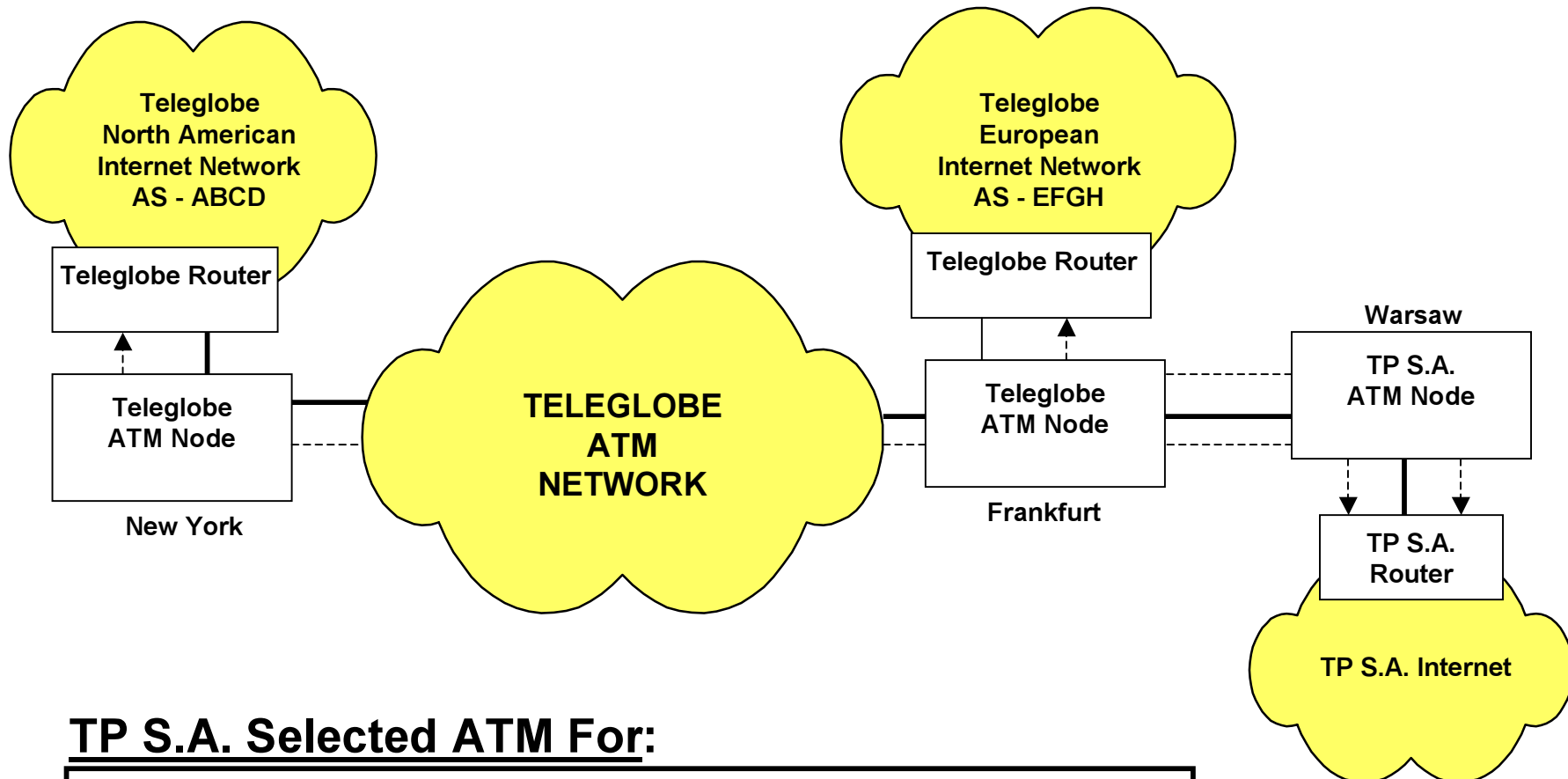

TP S.A. Selected ATM For:

- Scalable Internet Access
- Split European and North American traffic flows
- Dedicated access bandwidth to North American

Teleglobe Wholesale ATM Product

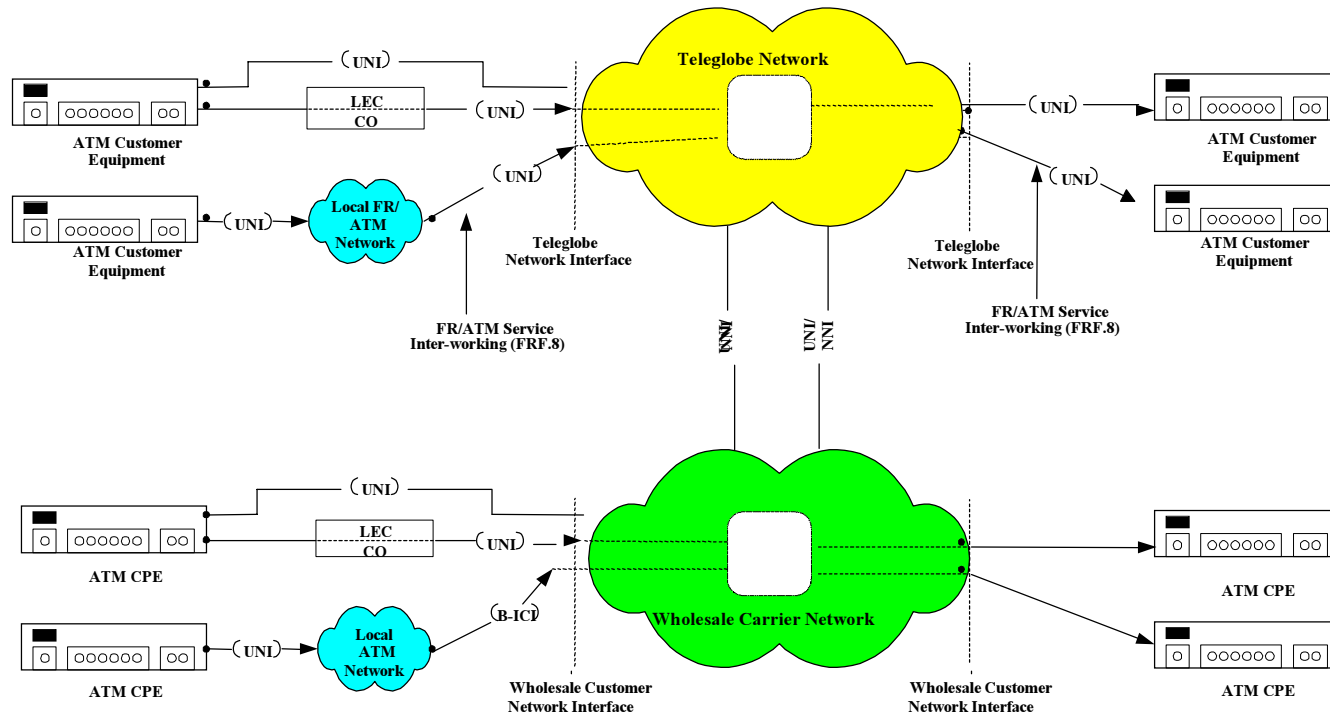

• Teleglobe to provide:

- Network Infrastructure
- Provisioning & Maintenance
- Access Service Coordination
- Service Billing

PVC Service:

- T1;E1;E3;DS3;STM-1 Ports
- CBR; VBR; VBR-rt; UBR

Service Adaptation:

- FR-to-ATM(FRF.8)
- E1/T1 CES (AAL1)

• UNI/NNI Interconnect

Technical Framework:

- End-to-End Service Description at UNI
- Inter-Operator Agreement at NNI
- Service Performance Objectives

Operations Framework:

- Service Provisioning
- Network Monitoring
- Fault Handling
- Planned Maintenance

Commercial Framework:

- Presales Customer Inquires
- One-Stop Shopping
- Service Pricing

Case Study #2 - KDD

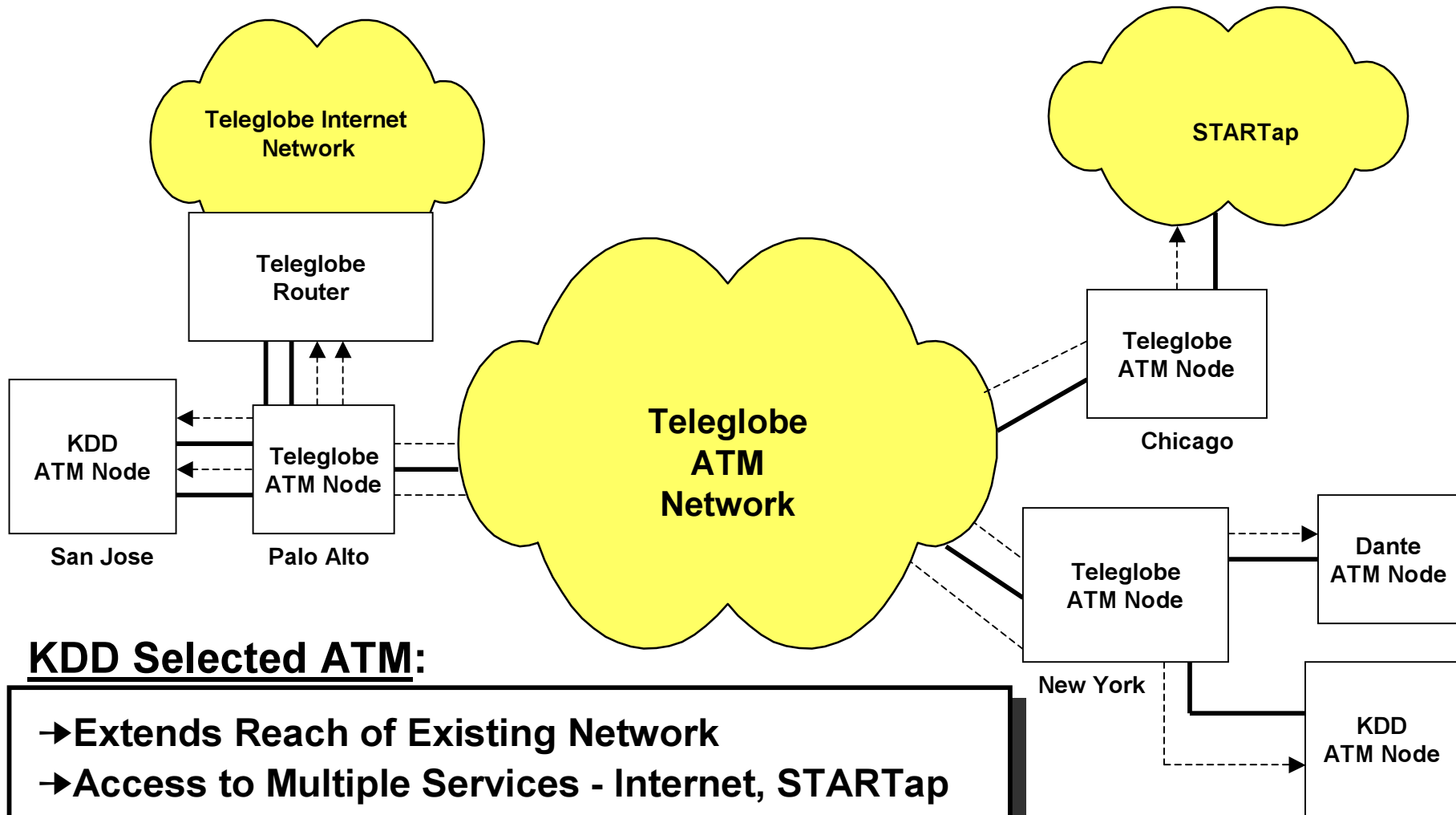

KDD Selected ATM:

- Extends Reach of Existing Network
- Access to Multiple Services - Internet, STARTap
- One-stop shopping, provisioning, monitoring, maintenance

ATM Multi-Service Access Product

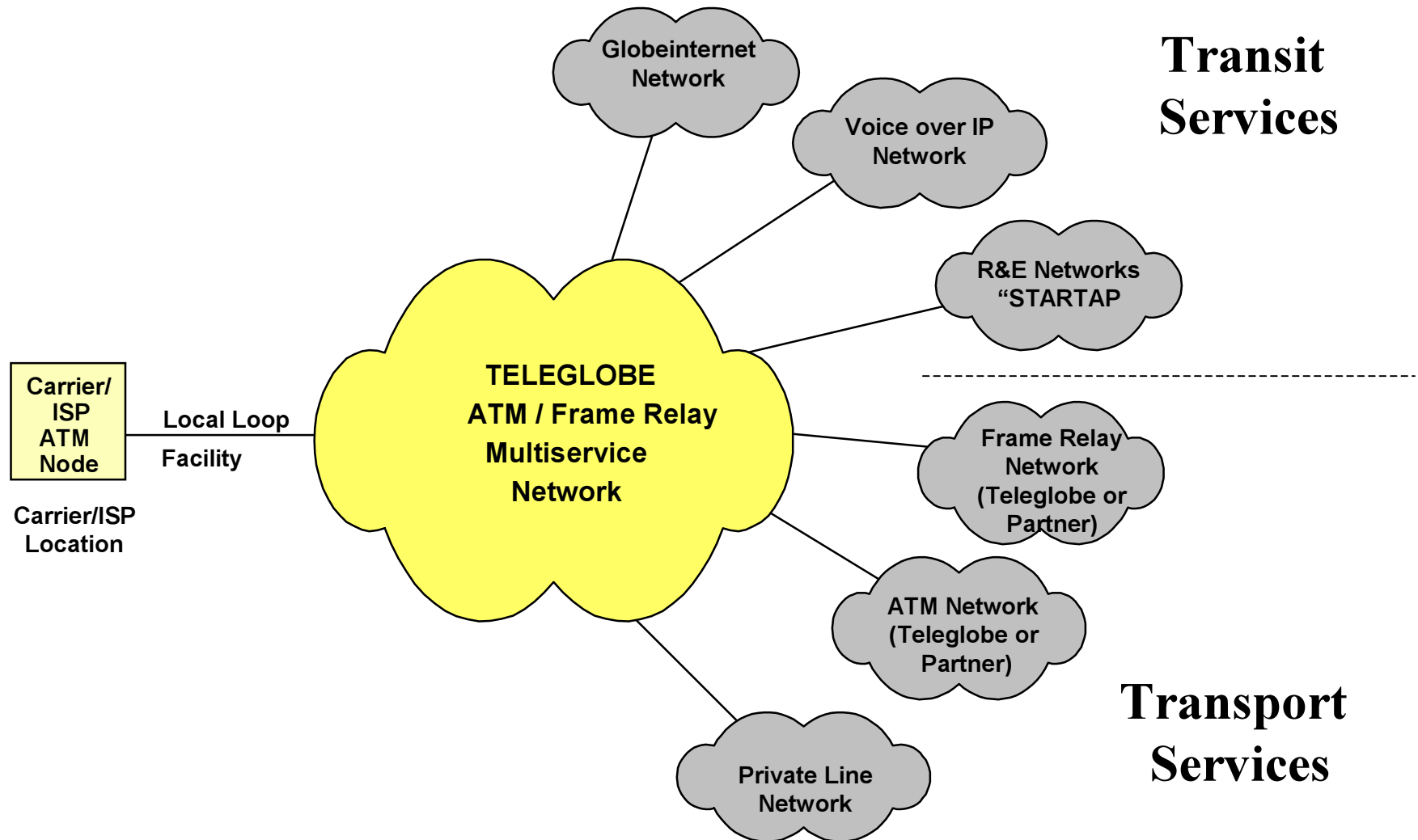

Case Study #3 - SPT TELECOM, a.s.

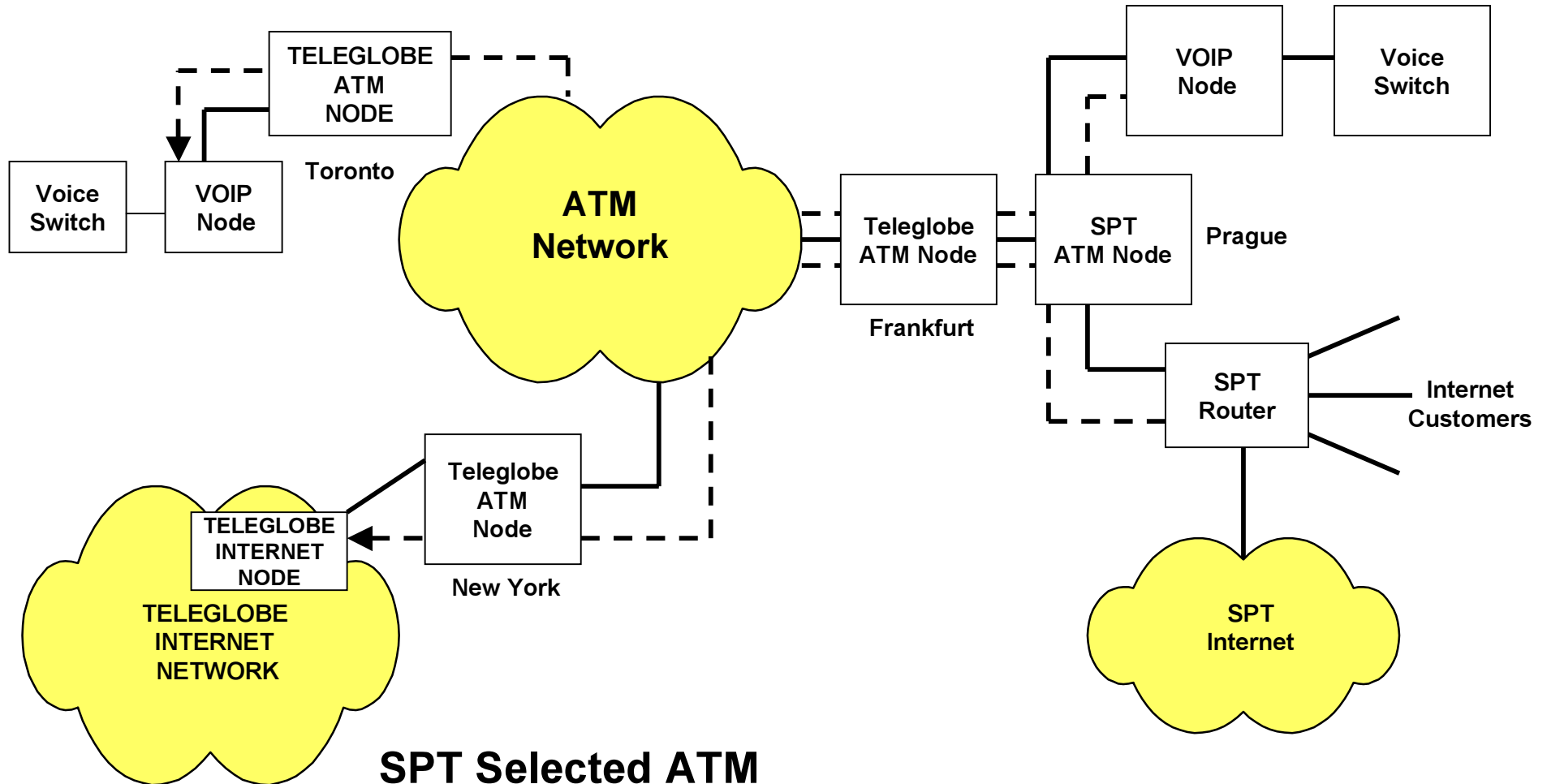

SPT Selected ATM

- Multi-Service Access
- Maximize Access Circuit Utilization
- Scalable and Flexible Transmission Media

Research and Education Service Configuration

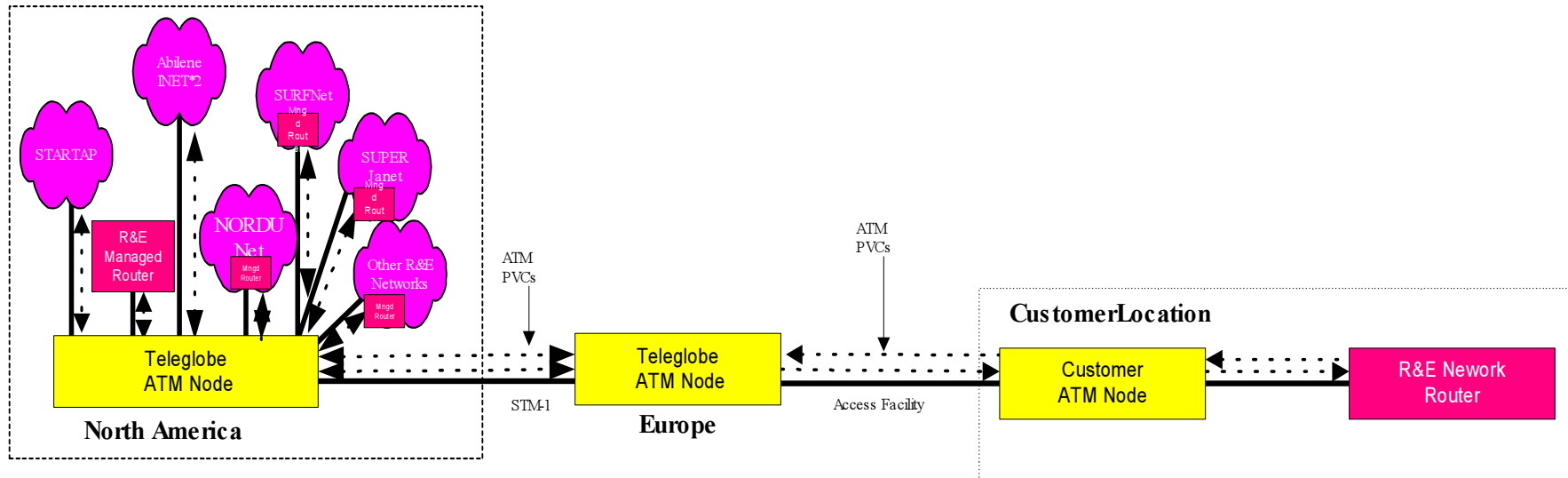

- Access to Major R&E Networks/Hubs in North America (Abilene, STARTAP)
- Access to R&E Network who co-locate in Teleglobe PoPs (Managed Routers)
- Scalable Bandwidth
- R&E Virtual TAP - Connections at ATM level
- Managed Router Service

Case Study #4 - University of Tennessee/Moscow University

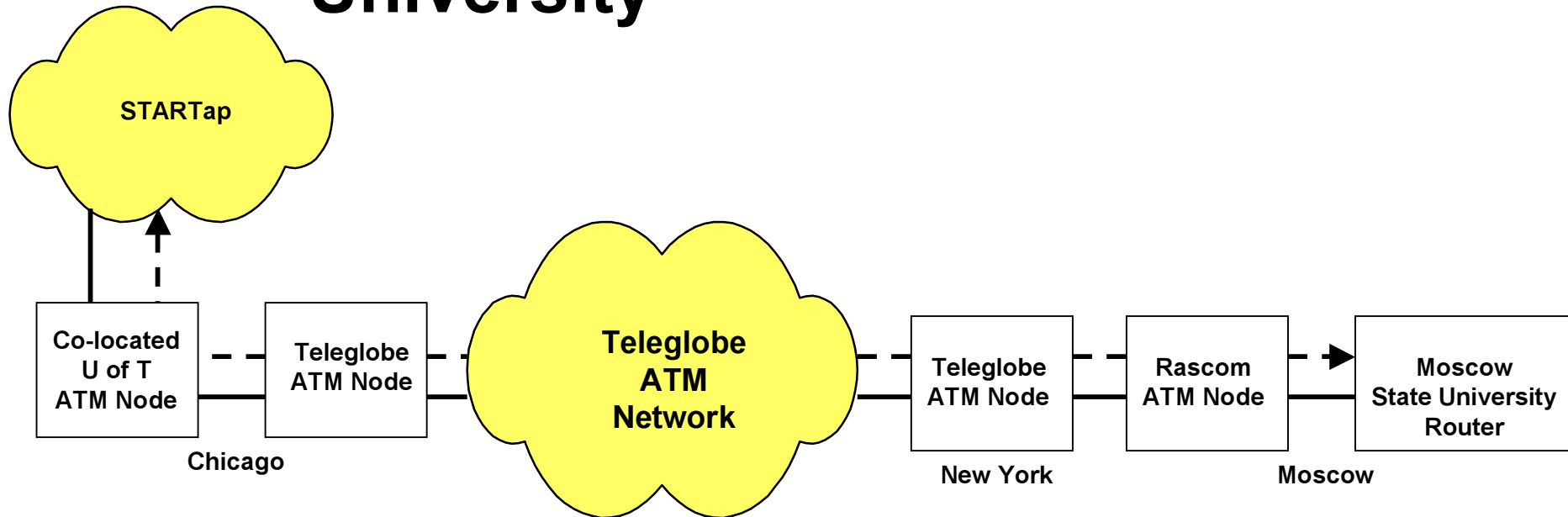

University of Tennessee Selected ATM

- Scalable and Dedicated Access
- Controlled Peering
- Access to Research and Education Networks
- Co-located Customer equipment

Circuit Emulation (AAL1) Service Configuration

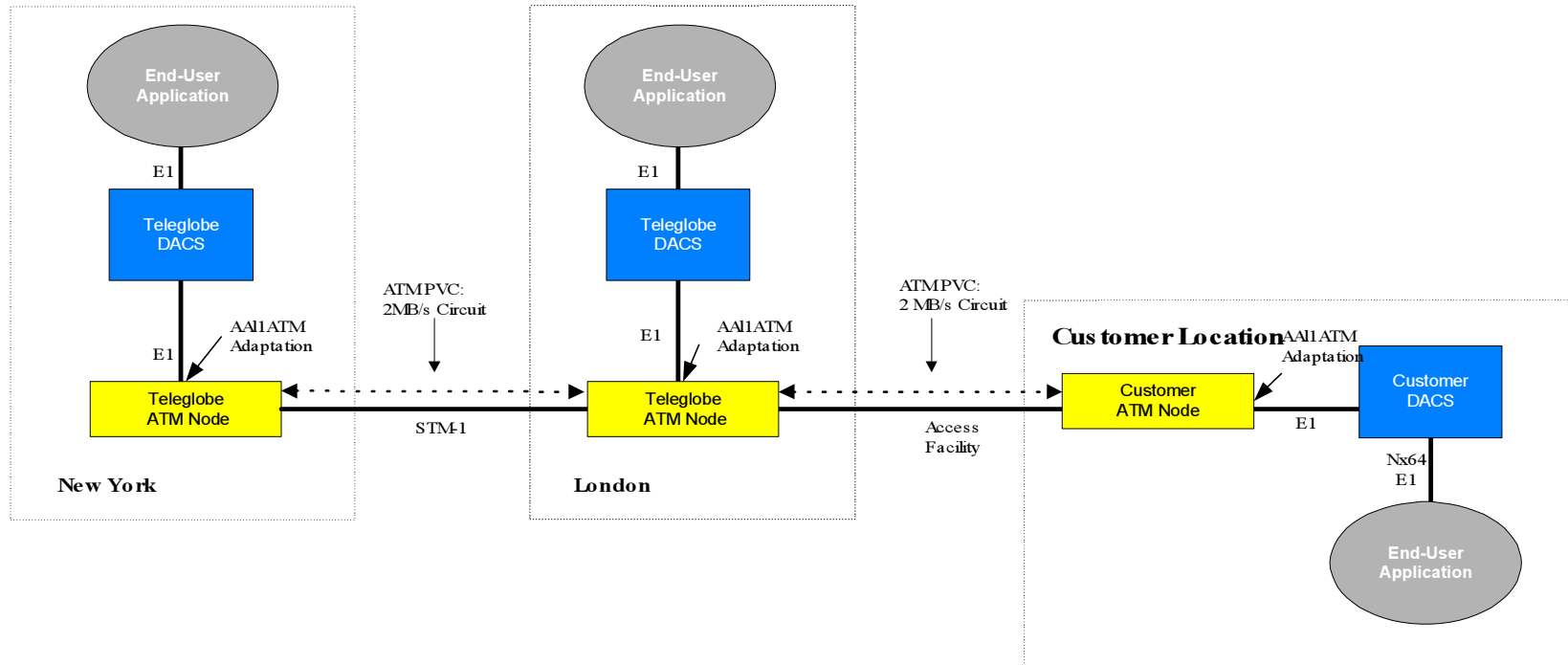

- Access to Teleglobe's DACS
- Nx64 and E1 Private Line for Special Applications
- Access to Global Locations via Teleglobe's ATM or DACS Network
- One Stop Shopping

Voice Service Configuration

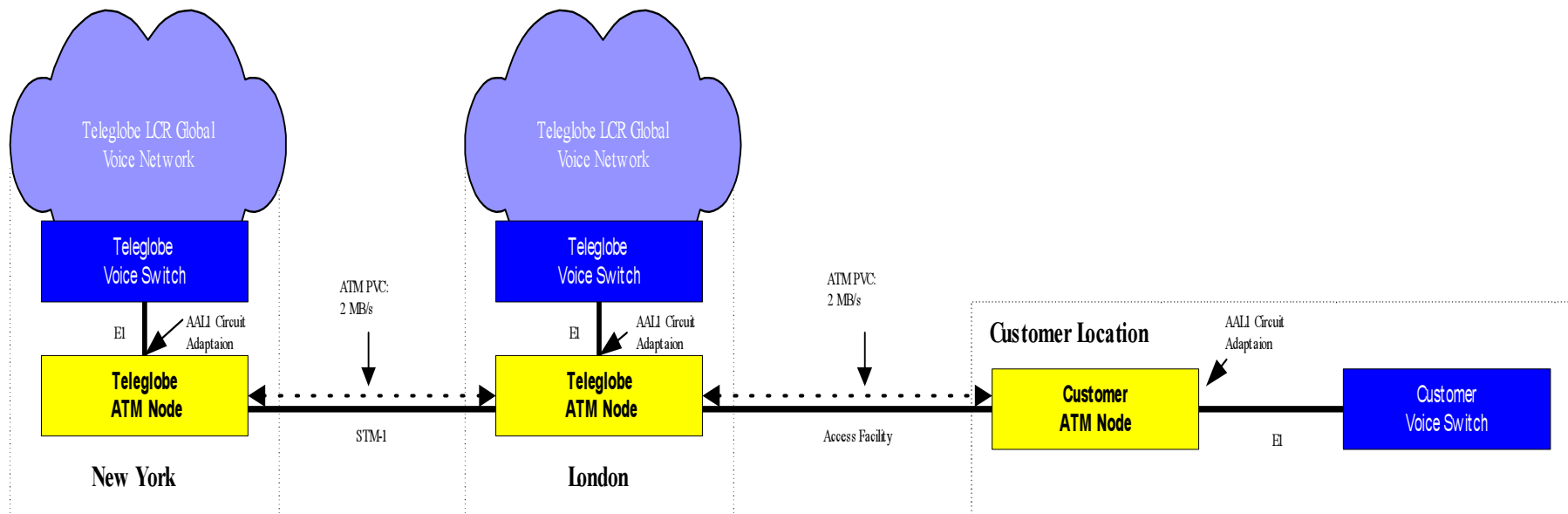

- **Access Teleglobe Voice Network**
- **2 MB/s Capacity - Inbound/Outbound Calls**
- **Call detail records from voice switch**
- **Overflow Bandwidth for Peak-Hour Utilization**

ATM Product Components

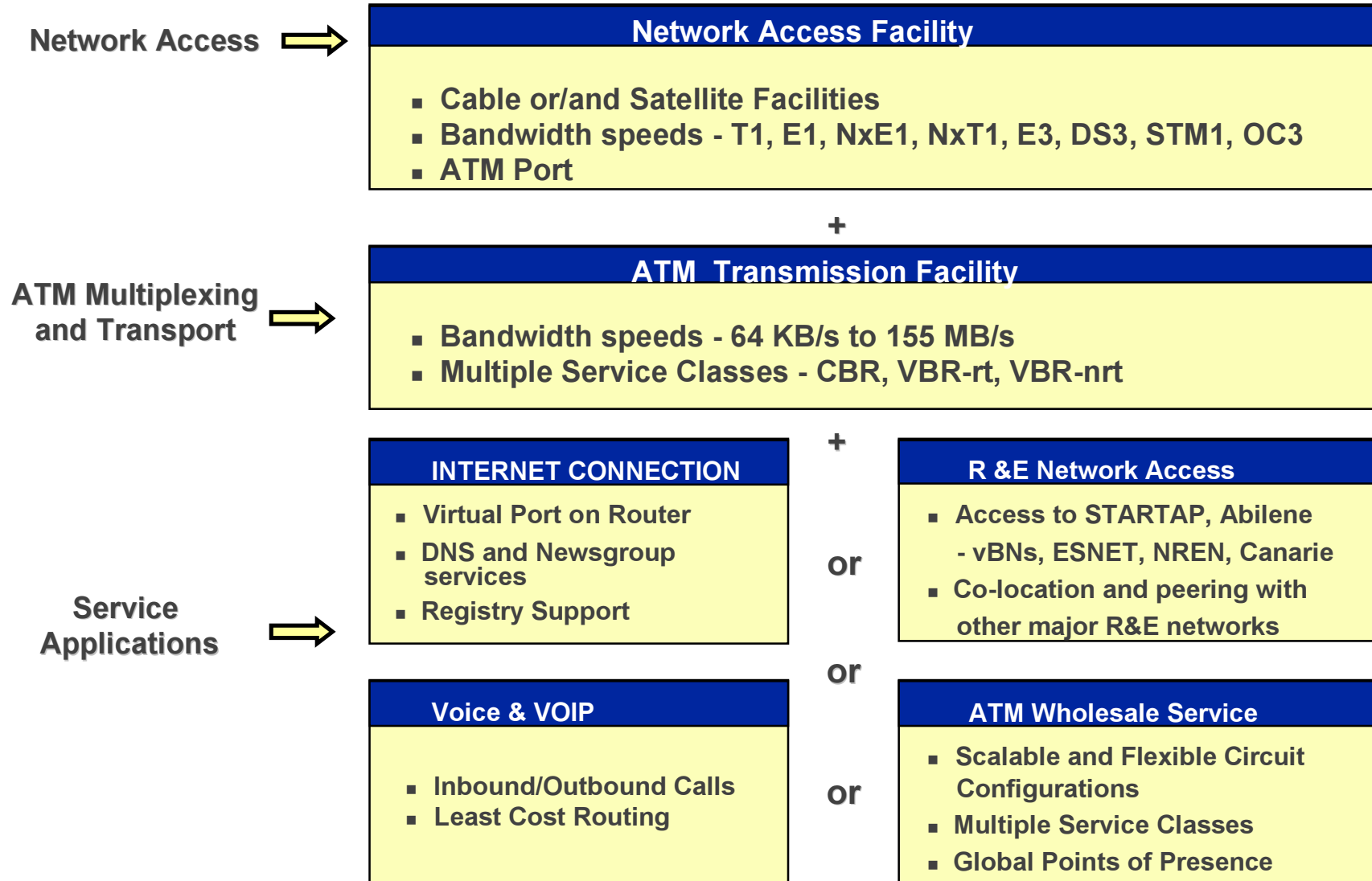

FR Product Overview

Teleglobe Wholesale Frame Relay Product

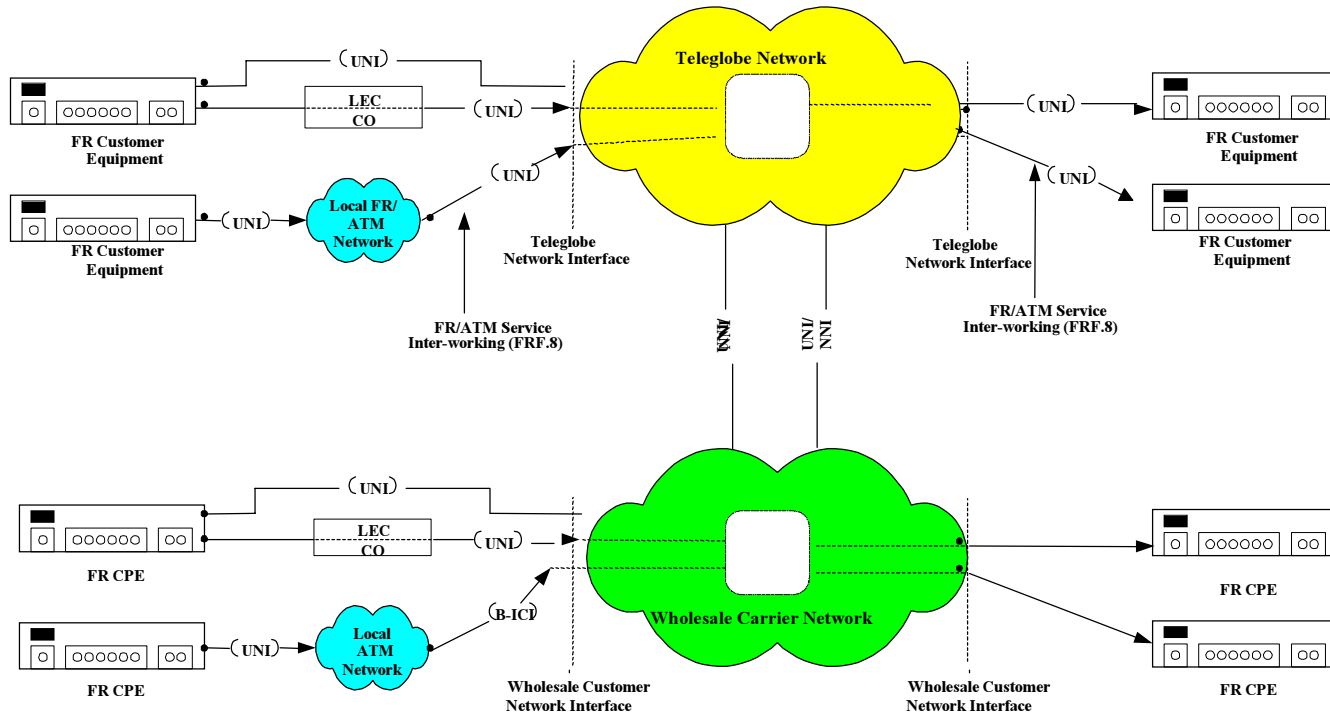

• Teleglobe to provide:

- Network Infrastructure
- Provisioning & Maintenance
- Access Service Coordination
- Service Billing

PVC Service:

- T1;E1;E3;DS3;STM-1 Ports
- CBR; VBR; VBR-rt; UBR

Service Adaptation:

- FR-to-ATM(FRF.8)
- E1/T1 CES (AAL1)

• UNI/NNI Interconnect

Technical Framework:

- End-to-End Service Description at UNI
- Inter-Operator Agreement at NNI
- Service Performance Objectives

Operations Framework:

- Service Provisioning
- Network Monitoring
- Fault Handling
- Planned Maintenance

Commercial Framework:

- Presales Customer Inquires
- One-Stop Shopping
- Service Pricing

Case Study #1 - AT&T

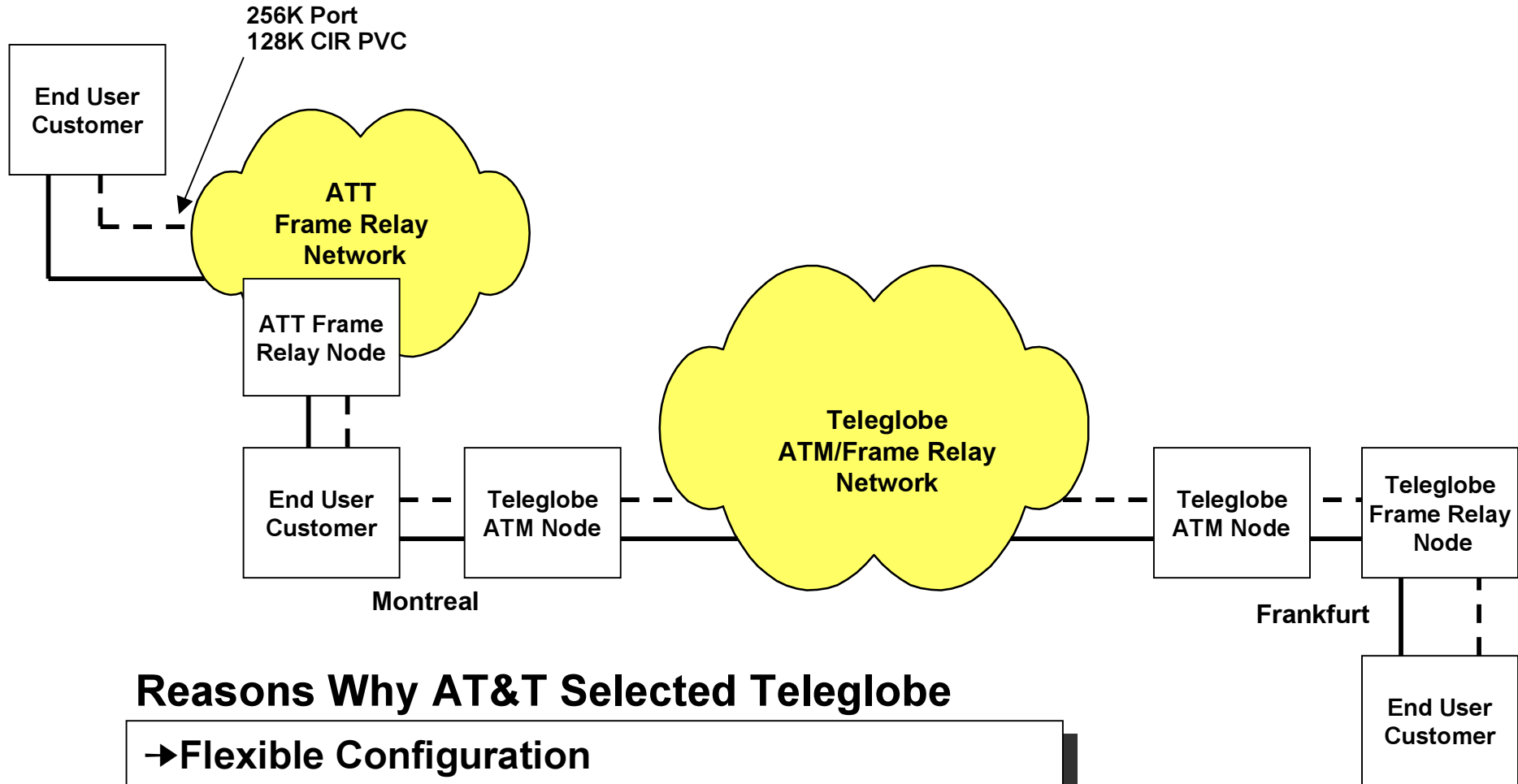

Reasons Why AT&T Selected Teleglobe

- Flexible Configuration
- Cost Effective Solution
- One Stop Shopping

VOIP over Frame Relay

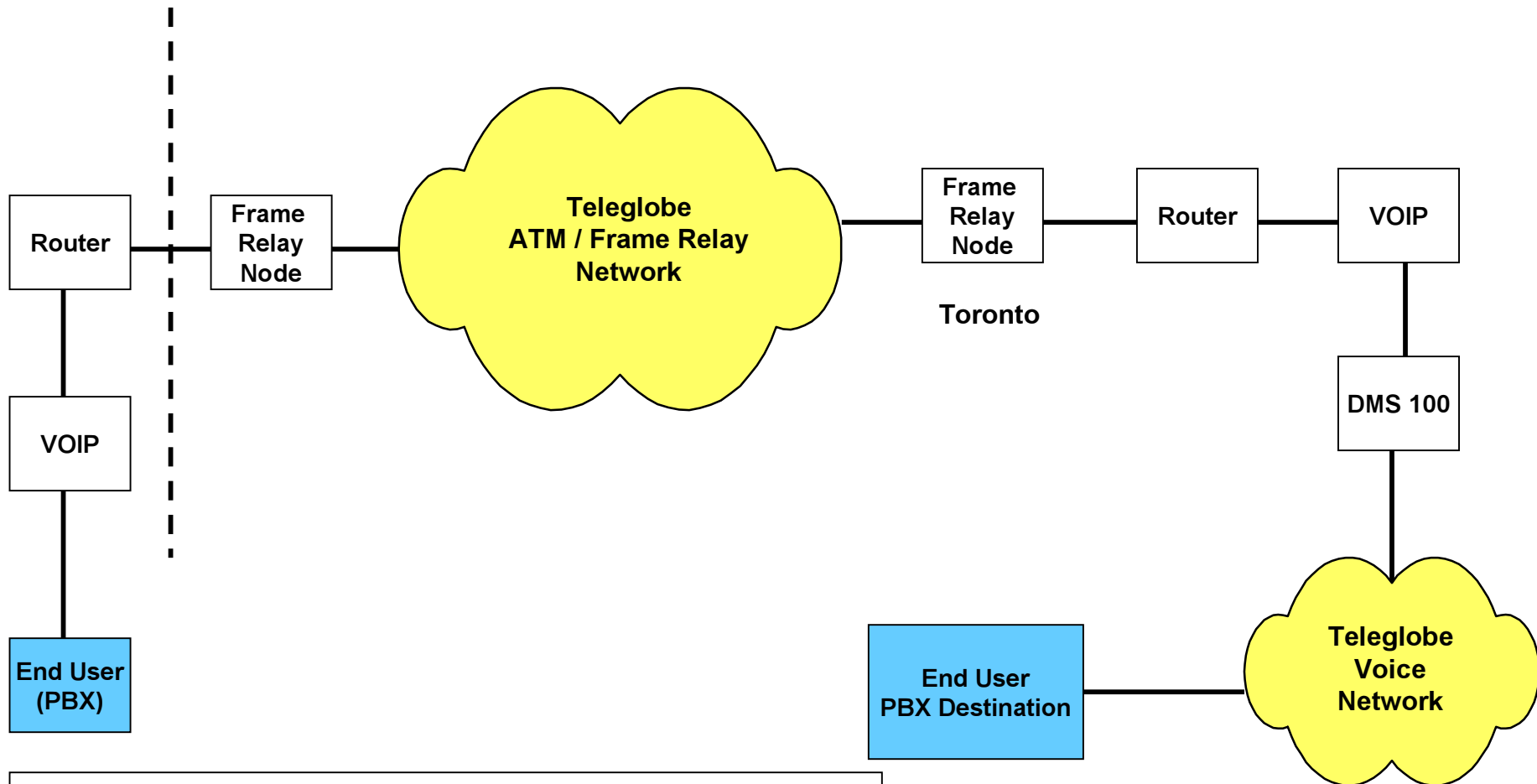

- Multi-Service Access
- Maximize Access Circuit Utilization
- Scalable and Flexible Transmission Media

Frame Relay Service Components

Network Access →

Network Access Facility
<ul style="list-style-type: none"> ▪ Cable or/and Satellite Facilities ▪ Bandwidth speeds - 56/64Kbps - T1/ E1 ▪ Frame Relay Port

+

Frame Relay Multiplexing and Transport →

Frame Relay Transmission Facility
<ul style="list-style-type: none"> ▪ Bandwidth speeds - 64 KB/s to 155 MB/s ▪ Flexible Port to CIR Ratios - 2:1 and 4:1

+

Service Applications →



Frame Relay
<ul style="list-style-type: none"> ▪ Scalable and Flexible Circuit Configurations <ul style="list-style-type: none"> ▪ Multiple Service Classes ▪ Global Points of Presence

OR

Voice over IP
<ul style="list-style-type: none"> ▪ Termination of IP voice traffic on the PSTN ▪ Transport of voice traffic over Teleglobe's IP network

Pricing

ATM/Frame Relay Pricing Structure

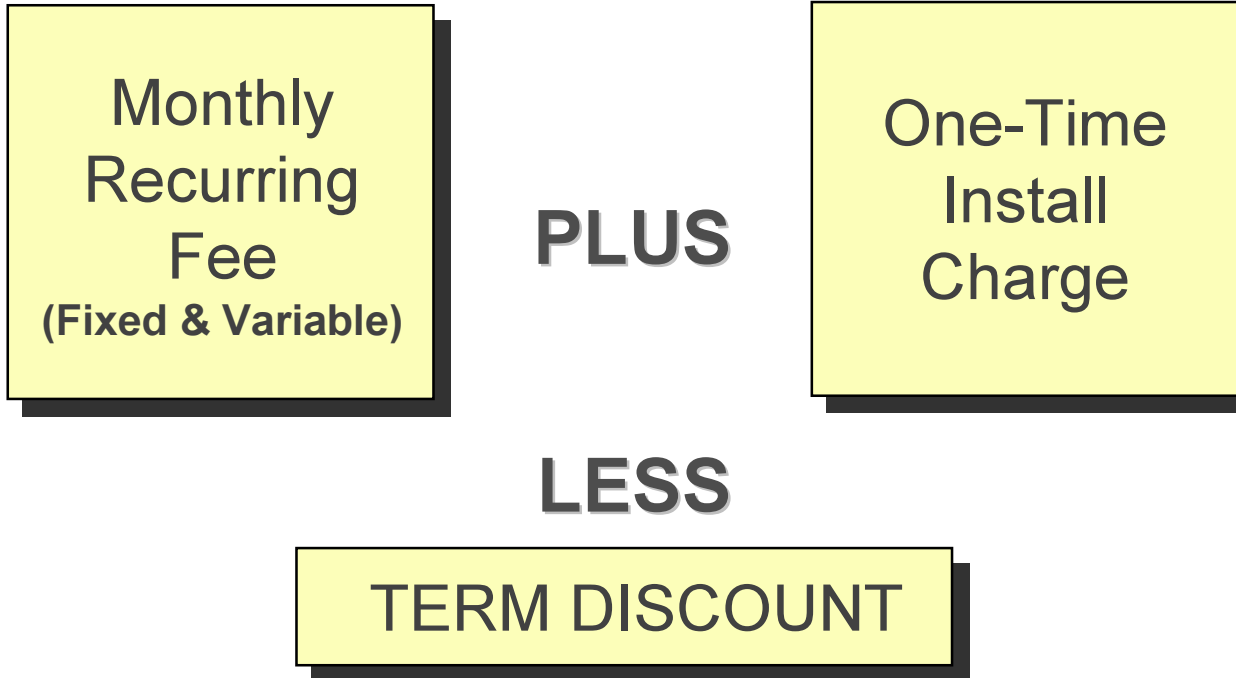

- Fixed Monthly Recurring Fee - Access Circuit and Port Fee
- Variable Monthly Recurring Fee - varies by Location, Application, Transmission Facility, Service Class and Bandwidth.

ATM/FR Recurring Fees

**Enhanced
Service Fees**

**Internet Transit Service
VOIP Service R&E Service**

+

**Incremental
ATM / FR
Circuit Fee**

**ATM/Frame Relay
Bearer Service**

+

**Fixed Minimum
Monthly Fee**

**Access Facility Fee
And ATM Port Fee**

Trouble Reporting

Teleglobe ATMSM Customer Support and Network



- **ISO 9002 certified support center located in Montreal, Canada**
- **Staffed 24 hours a day, 7 days a week**
- **Monitors all links and equipment**
- **Remedy Trouble Ticket System for tracking problem resolution**
- **Detailed escalation procedure and response thresholds**
- **Special Investigation of trouble tickets available upon request**

Customer Technical Support

General Information

- Tickets handled by the Global Customer Service Centre (GCSC) - Montreal
- Hours of Operation are 24X7
- English speaking and multilingual staff available for customer support

Fault Reporting

- Tickets handled by Remedy System
- Customer reports faults via phone, fax, email
- Customer provide - name, company, circuit ID, fault description, date & time of fault.

Customer Technical Support - Cont.

GCSC Feedback

- Major Fault -Service Outage
 - Initial response in 30 minutes
 - Next report within 2 hours
- Minor Fault - Service Degradation
 - Initial response in 2 hours
 - Next report within 8 hours

Escalation Procedure

- Customer Requests Escalation of Ticket
- Multiple Escalation Tiers
- Response to Escalation within 30 minutes.

Product Summary

GlobeATM

Advantages & Benefits

Advantages	Benefits
Wholesale Service Offering	Focused on enhancing, rather than competing with, the local/regional carrier's service offerings.
Single Point of Contact	Single point order for multiple services. One-stop shopping.
Carrier Grade Facilities	Highest-quality service.
Open Standards Support	Supports multi-vendor Equipment.
Flexible Bandwidth	Scaleable bandwidth to match service Requirement.
Multiple Service Classes	Provides QoS specific for Application.
Multiple Applications	Access to Teleglobe's Voice, Internet, Private-Line and R&E Networks.
24/7 Support/ISO 9001 Compliant Customer Support Center	Around-the-clock top-quality support from our ISO 9001 compliant Network Operations and Customer Support Center.

Qualifying Frame Relay Opportunities

- Does the customer have costly operations because their current network configuration contains private lines to communicate between locations that need to be interconnected?
- Does the customer have a large number of offices that need to be interconnected (4 or more locations at speeds between 56/64K and 2Mbps)?
- Are the customer's applications 'bursty' with traffic being transmitted over relatively short periods in bursts (e.g. data intensive applications such as document/file and graphics sharing, LAN interconnection, file transfers, remote database access, e-mail or remote to host or mainframe to mainframe connections)?
- Does the customer need to reduce the size of their networking staff?
- Does the customer need an easy migration path to higher speed broadband technologies such as ATM?
- Does the customer need to consolidate separate private line networks such as LAN internetworks and SNA traffic?

Qualifying ATM Opportunities

- Does the customer have multimedia communications requirements (voice, video and data)?
- Does the customer have bandwidth requirements between 2Mb/s and 150Mb/s?
- Does the customer have an existing Time Division Multiplexing environment in which they require bandwidth granularity and scalability?
- Does the customer require asymmetrical circuits or a point to multi-point network configuration?
- Does the customer require internet access service?
- Does the customer need to provide local Research and Education (R&E) Networks with access to North American R&E networks?
- Does the customer need to scale or increase bandwidth on an ongoing basis?
- Does the customer require ATM service to an international location where they do not have a Point of Presence?

Děkuji za pozornost.

Teleglobe Int'l Corp.
Klimentská 46, 110 02 Praha 1
fsamla@teleglobe.cz
Tel. : + 420 2 2185 2360
Fax : + 420 2 2185 2090

<http://www.teleglobe.com>